



GLOBAL GREEN CORPORATION

20 Watt LED Flood Light

Industrial Grade LED Flood Light



Phillips
3030

20 Watt

82 CRI

50000hrs



FEATURES

- Phillips 3030 Chips
- 100-277AC or 305 AC
- Replaces 75W Metal Halide
- Environmentally friendly; no mercury or lead
- 5 year product warranty
- Choice of 2700K, 3000K, 3500K, 4000K or 5000K
- Frosted lens for uniform diffuse appearance
- Up to 80% energy savings
- Ultra-high performance LED delivers 130 lpw
- Suitable for dry or damp locations
- Emergency Battery Back Up Available
- DALI Dimmable Driver Available



DIMENSIONS

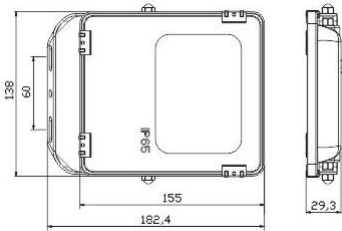

APPLICATIONS

- Schools
- Offices
- Warehouses
- Hospitals
- Subways
- Stores

SPECIFICATIONS

Watts	Volts	Lumens	Beam Angle	CCT	CRI
20W	AC120-277V	2,600 lm	120 degrees	2700K/3000K/3500k/4000K	>82
Efficiency	PF	Mode	IP Rating	Rated Life	Approvals
130lm/W	>0.95	Dimmable or Dali	65	50000hrs	UL/cUL, DLC V 4.0

ORDERING GUIDE

Example: GG-FLD1-DIM-20W-840

Company	Series	Mode	Watts	CCT
GG - Global Green	FLD1	DIM- DALI	20	840 - 4000K
				850 - 5000K
				857 - 5700K

30 Watt LED Flood Light

Industrial Grade LED Flood Light



Phillips
3030

30 Watt

82 CRI

50000hrs



FEATURES

- Phillips 3030 Chips
- 100-277AC or 305 AC
- Replaces 75W Metal Halide
- Environmentally friendly; no mercury or lead
- 5 year product warranty
- Choice of 2700K, 3000K, 3500K, 4000K or 5000K
- Frosted lens for uniform diffuse appearance
- Up to 80% energy savings
- Ultra-high performance LED delivers 130 lpw
- Suitable for dry or damp locations
- Emergency Battery Back Up Available
- DALI Dimmable Driver Available



DIMENSIONS

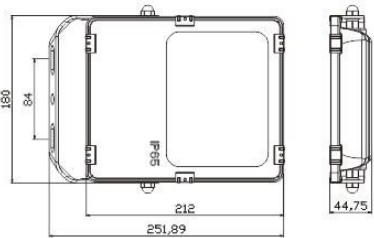

APPLICATIONS

- Schools
- Offices
- Warehouses
- Hospitals
- Subways
- Stores

SPECIFICATIONS

Watts	Volts	Lumens	Beam Angle	CCT	CRI
30W	AC120-277V	3,900 lm	120 degrees	2700K/3000K/3500k/4000K	>82
Efficiency	PF	Mode	IP Rating	Rated Life	Approvals
130lm/W	>0.95	Dimmable or Dali	65	50000hrs	UL/cUL, DLC V 4.0

ORDERING GUIDE

Example: GG-FLD1-DIM-30W-840

Company	Series	Mode	Watts	CCT
GG - Global Green	FLD1	DIM- DALI	30	840 - 4000K
				850 - 5000K
				857 - 5700K



GLOBAL GREEN CORPORATION

50 Watt LED Flood Light

Industrial Grade LED Flood Light

FEATURES

- Phillips 3030 Chips
- 100-277AC or 305 AC
- Replaces 175W Metal Halide
- Environmentally friendly; no mercury or lead
- 5 year product warranty
- Choice of 2700K, 3000K, 3500K ,4000K or 5000K
- Frosted lens for uniform diffuse appearance
- Up to 80% energy savings
- Ultra-high performance LED delivers 130 lpw
- Suitable for dry or damp locations
- Emergency Battery Back Up Available
- DALI Dimmable Driver Available



Phillips
3030

50 Watt

82 CRI

50000hrs



DIMENSIONS

APPLICATIONS

- Schools
- Offices
- Warehouses
- Hospitals
- Subways
- Stores

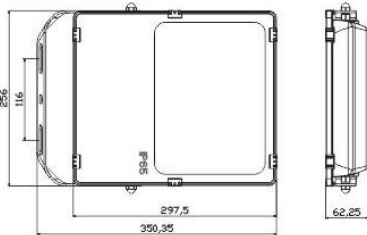

SPECIFICATIONS

Watts	Volts	Lumens	Beam Angle	CCT	CRI
50W	AC120-277V	6,500 lm	120 degrees	2700K/3000K/3500k/4000K	>82
Efficiency	PF	Mode	IP Rating	Rated Life	Approvals
130lm/W	>0.95	Dimmable or Dali	65	50000hrs	UL/cUL, DLC V 4.0

ORDERING GUIDE

Example: GG-FLD1-DIM-50W-840

Company	Series	Mode	Watts	CCT
GG - Global Green	FLD1	DIM- DALI	50	840 - 4000K
				850 - 5000K
				857 - 5700K



GLOBAL GREEN CORPORATION

70 Watt LED Flood Light

Industrial Grade LED Flood Light



Phillips
3030

70 Watt

82 CRI

50000hrs



FEATURES

- Phillips 3030 Chips
- 100-277AC or 305 AC
- Replaces 175W Metal Halide
- Environmentally friendly; no mercury or lead
- 5 year product warranty
- Choice of 2700K, 3000K, 3500K, 4000K or 5000K
- Frosted lens for uniform diffuse appearance
- Up to 80% energy savings
- Ultra-high performance LED delivers 130 lpw
- Suitable for dry or damp locations
- Emergency Battery Back Up Available
- DALI Dimmable Driver Available



DIMENSIONS

APPLICATIONS

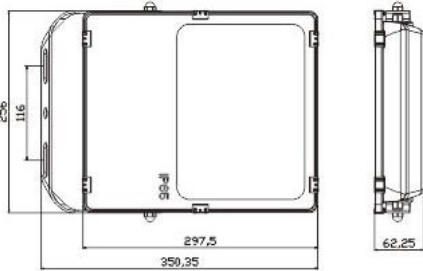

- Schools
- Offices
- Warehouses
- Hospitals
- Subways
- Stores

SPECIFICATIONS

Watts	Volts	Lumens	Beam Angle	CCT	CRI
70W	AC120-277V	9,100 lm	120 degrees	2700K/3000K/3500k/4000K	>82
Efficiency	PF	Mode	IP Rating	Rated Life	Approvals
130lm/W	>0.95	Dimmable or Dali	65	50000hrs	UL/cUL, DLC V 4.0

ORDERING GUIDE

Example: GG-FLD1-DIM-70W-840

Company	Series	Mode	Watts	CCT
GG - Global Green	FLD1	DIM- DALI	70	840 - 4000K
				850 - 5000K
				857 - 5700K



GLOBAL GREEN CORPORATION

100 Watt LED Flood Light

Industrial Grade LED Flood Light



Phillips
3030

100 Watt

82 CRI

50000hrs



FEATURES

- Phillips 3030 Chips
- 100-277AC or 305 AC
- Replaces 250W Metal Halide
- Environmentally friendly; no mercury or lead
- 5 year product warranty
- Choice of 3000K, 3500K, 4000K or 5000K
- Frosted lens for uniform diffuse appearance
- Up to 80% energy savings
- Ultra-high performance LED delivers 130 lpw
- Suitable for dry or damp locations
- Emergency Battery Back Up Available
- DALI Dimmable Driver Available



DIMENSIONS

APPLICATIONS

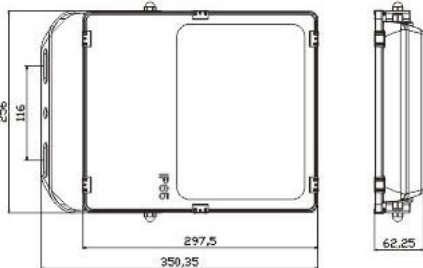

- Schools
- Offices
- Warehouses
- Hospitals
- Subways
- Stores

SPECIFICATIONS

Watts	Volts	Lumens	Beam Angle	CCT	CRI
100W	AC120-277V	13,000 lm	120 degrees	2700K/3000K/3500k/4000K	>82
Efficiency	PF	Mode	IP Rating	Rated Life	Approvals
130lm/W	>0.95	Dimmable or Dali	65	50000hrs	UL/cUL, DLC V 4.0

ORDERING GUIDE

Example: GG-FLD1-DIM-100W-840

Company	Series	Mode	Watts	CCT
GG - Global Green	FLD1	DIM- DALI	100	840 - 4000K
				850 - 5000K
				857 - 5700K

150 Watt LED Flood Light

Industrial Grade LED Flood Light

FEATURES

- Phillips 3030 Chips
- 100-277AC or 305 AC
- Replaces 250W Metal Halide
- Environmentally friendly; no mercury or lead
- 5 year product warranty
- Choice of 3000K, 3500K ,4000K or 5000K
- Frosted lens for uniform diffuse appearance
- Up to 80% energy savings
- Ultra-high performance LED delivers 130 lpw
- Suitable for dry or damp locations
- Emergency Battery Back Up Available
- DALI Dimmable Driver Available



Phillips
3030

150 Watt

82 CRI

50000hrs



DIMENSIONS

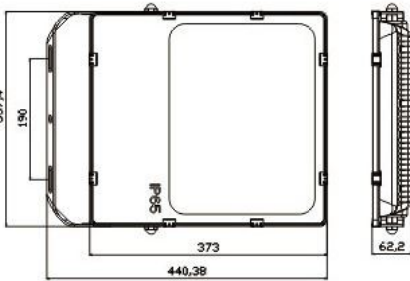

APPLICATIONS

- Schools
- Offices
- Warehouses
- Hospitals
- Subways
- Stores

SPECIFICATIONS

Watts	Volts	Lumens	Beam Angle	CCT	CRI
150W	AC120-277V	19,500 lm	120 degrees	2700K/3000K/3500k/4000K	>82
Efficiency	PF	Mode	IP Rating	Rated Life	Approvals
130lm/W	>0.95	Dimmable or Dali	65	50000hrs	UL/cUL, DLC V 4.0

ORDERING GUIDE

Example: GG-FLD1-DIM-150W-840

Company	Series	Mode	Watts	CCT
GG - Global Green	FLD1	DIM- DALI	150	840 - 4000K
				850 - 5000K
				857 - 5700K



GLOBAL GREEN CORPORATION

200 Watt LED Flood Light

Industrial Grade LED Flood Light



Phillips
3030

200 Watt

82 CRI

50000hrs



FEATURES

- Phillips 3030 Chips
- 100-277AC or 305 AC
- Replaces 250W Metal Halide
- Environmentally friendly; no mercury or lead
- 5 year product warranty
- Choice of 3000K, 3500K, 4000K or 5000K
- Frosted lens for uniform diffuse appearance
- Up to 80% energy savings
- Ultra-high performance LED delivers 130 lpw
- Suitable for dry or damp locations
- Emergency Battery Back Up Available
- DALI Dimmable Driver Available



DIMENSIONS

APPLICATIONS

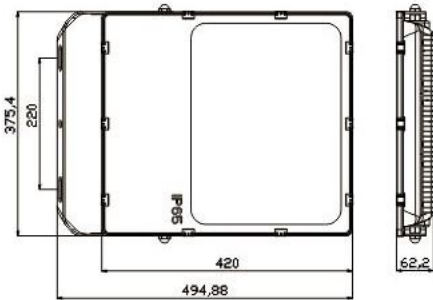

- Schools
- Offices
- Warehouses
- Hospitals
- Subways
- Stores

SPECIFICATIONS

Watts	Volts	Lumens	Beam Angle	CCT	CRI
200W	AC120-277V	26,000 lm	120 degrees	2700K/3000K/3500k/4000K	>82
Efficiency	PF	Mode	IP Rating	Rated Life	Approvals
130lm/W	>0.95	Dimmable or Dali	65	50000hrs	UL/cUL, DLC V 4.0

ORDERING GUIDE

Example: GG-FLD1-DIM-200W-840

Company	Series	Mode	Watts	CCT
GG - Global Green	FLD1	DIM- DALI	200	840 - 4000K
				850 - 5000K
				857 - 5700K